

100S READOUTS

FOR GENERAL PURPOSE

APPLICATIONS



ACU-RITE®

REFERENCE MANUAL

General

Overview	1
Preparation	2
Packing List	2
Warranty Records	2
Installing the Scales	3
Installing the Readout	3
Power Up	4
Display Saver	4

Setup

Parameter Setup	5
Display Resolution	6
Linear Error Compensation	7
How to Determine the Linear Error Compensation	8
Scale Resolution	9
Count Direction	9
Radius/Diameter	10
Position Recall	10
Testing the Scales	10

Operation

Power On Position Recovery	11
Position Recall	11
Reference Mark Evaluation	12
Radius and Diameter	12
Setting the Datum (Absolute Zero)	13
Example: Setting Up Your Job	14
Incremental Dimensions	15
Example: Incremental Dimensions	16
Absolute and Incremental Presets	17

Table Of Contents

Troubleshooting

Troubleshooting Introduction	18
General	19
Error Messages (General)	23
(Keypad Test)	24

Reference

Electrical Specifications	25
Factory Default Settings	26
Keypad	27
Conventions	29
Count Direction	29

Overview

This manual will guide you through the installation, setup, and operation of the **100S GP** system. Use it to get your system up and running “out of the box” and as a quick reference guide for your day-to-day operations.

Here’s how a typical machine will look after the installation is complete:

100S GP Readout

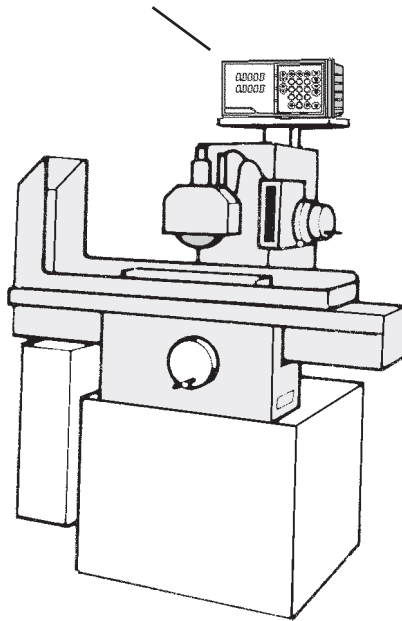

General

Preparation

Packing List

Verify that you have received all of the components for your system:

- Readout instructions
- Installation instructions
- Mounting arm
- **ENC 125** scales
 - Cable mounting hardware
 - Scale mounting hardware
- Warranty card

If a component is missing, contact your **100S GP** distributor immediately for replacement.

Warranty Records

Complete the warranty card included with your **100S GP** system. The readout's catalog and serial numbers are on the back of the display; the scale's catalog number is on the scale assembly label; and the serial number is on the scale case.

Copy the information here for your own records and mail the warranty card as soon as possible.

	Catalog No.	Serial No.
Axis # 1:	_____	_____
Axis # 2:	_____	_____
Axis # 3:	_____	_____
Date of purchase:	_____	
Distributor:	_____	
Address:	_____	
Telephone:	_____	

Installing the Scales

Please see the manual included with the scale for installation instructions.

Installing the Readout

Follow the readout installation instructions that are included with your mounting arm bracket kit. The electrical specifications for the readout are listed on pg. 25.

General

Power Up

Press the switch on the back of the readout to power up the system. A series of tests will check that the display, keypad, and memory are all working properly.

If a problem is detected, an error code will appear on the screen. (Error messages and solutions are listed on pgs. 23 - 24.) It is important to note that the **E1 message** will appear every time you power up your system and does not indicate a problem. It merely indicates that the system had lost power. To acknowledge the message, press the **CLEAR** key and proceed to the DRO mode.

Note: If the E1 message appears at any other time during normal operation, refer to pg. 23 for possible problems and solutions.

Display Saver

When the system is not used for more than 90 minutes, a decimal point will “scroll” across the display, indicating that the display saver has been activated. The display saver, like a screen saver on a computer monitor, will help prolong the life of your readout.

If the display saver has been activated, press any key on the readout or move any axis to return to the normal DRO view.

Parameter Setup

These are the parameters that you can define on your system:

- Display resolution (diS)
- Linear error compensation (LEC)
- Scale resolution (rES)
- Scale count directions (Ct dir)
- Radius/Diameter (dIA)
- Position Recall (rECAll)

Establish each setting the first time you power up the system. You can change the parameters later by returning to Setup and then using the **ENTER** key to scroll to the appropriate category.

Anytime you change the linear error compensation, or count direction for an axis, the absolute and incremental displays for that axis will be reset to 0. If you change these settings, you'll need to reestablish the datum point.

When in the Setup mode, use the **CLEAR** key when you want to back-space, restore the previous value or access the previous parameter.

Setup

Display Resolution

The display resolution determines how detailed each scale's position will be displayed on the readout. Use the setting that best suits each job.

To change the display resolution:

- Press the **SETUP** key. (“diS” will show on the display.)
- Press the **AXIS** key for the display you want to change.

For 10 μ m scales, the display resolution will toggle between 0.01 mm (0.0005”) and 0.02 mm (0.001”). For 5 μ m scales, it will toggle between 0.005 mm (0.0002”) and 0.01 mm (0.0005”). For 1 μ m scales, it will toggle between 0.001 mm (0.00005”) and 0.002 mm (0.0001”).

- After you complete setting your display resolution, press **ENTER** to continue with setup or press **SETUP** to return to the normal DRO display.

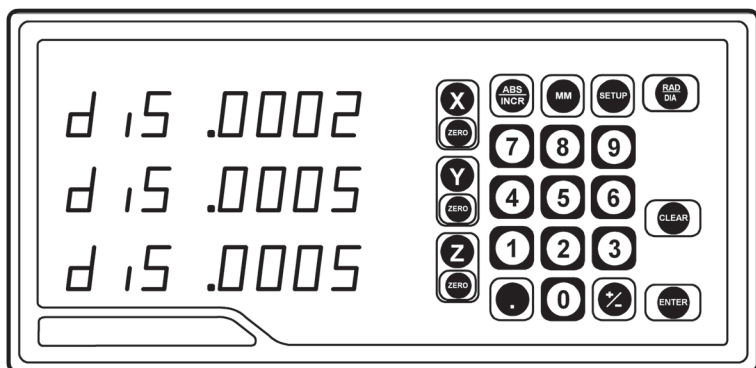

Linear Error Compensation

With **100S GP**, you can compensate for machine tool wear. If you know the linear error compensation (LEC) value in parts-per-million (PPM), you can enter it directly.

If you don't know the LEC, use the formula on the next page to determine the value for each axis.

To change the linear error compensation:

- Move to the “Linear Error Compensation” display in the Setup mode. (Press **SETUP** and then the **ENTER** key until “LEC” (appears).
- Press the **X** or **Z** key for the axis you want to change. **100S GP** will display the current LEC value for that axis.
- Using the keypad, enter the linear error compensation factor (in PPM), followed by the \pm key for negative values. The number must be within -9999 and 9999 (use whole numbers). The formula for calculating the value is on the next page.
- After you complete setting your LEC, press **ENTER** to continue with setup or press **ENTER** then **SETUP** to return to the normal DRO display.

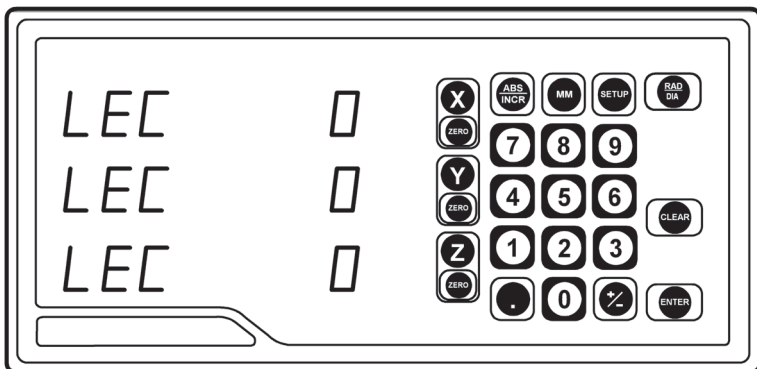

Setup

How to Determine the Linear Error Compensation

Follow this procedure for each axis:

- In the DRO mode.
- Place a standard of known length on the machine. Make sure it's parallel with the axis being measured.
- Put the readout in the absolute display mode (**ABS/INCR** key).
- Using an indicator, locate one end of the standard.
- Press the **ZERO** key twice for the axis you are measuring. "0" should appear on the display.
- Move the indicator along the axis until it reaches the opposite end of the standard.
- Write down the length that is shown on the readout display for that axis.
- Use the formula below to calculate the LEC for the axis you just measured. Enter the result in the LEC parameter (previous page).

Note: If the measured length is greater than the standard length the LEC value will be negative.

Formula

S = Standard length

M = Measuring length

$$LEC = \left(\frac{S - M}{M} \right) \times 1,000,000$$

Example

If the length of the standard you used is 10" and the measured length is 9.995", then the LEC for that axis is 500 parts-per-million (PPM).

$$LEC = \left(\frac{10 - 9.995}{9.995} \right) \times 1,000,000$$

500 PPM

$$LEC = \text{(rounded to the nearest whole number)}$$

Scale Resolution

To ensure accurate readings, the scale resolution shown for each axis must correspond with the resolution of the scales on your machine.

To change the scale resolution:

- If necessary, choose “Scale Resolution” from the Setup menu. (Press **SETUP** and then the **ENTER** key until the screen appears).
- Press the appropriate axis key (X, Y or Z) until the appropriate resolution appears. Choose 0.01 mm for 10 μ m (0.0005”) scales, 0.005 mm for 5 μ m (0.0002”) and 0.001 mm for 1 μ m (0.00005”) scales.
- Repeat the procedure for each axis.
- Press **ENTER** to continue with Setup.

Count Direction

Use the count direction setting to define the positive counting direction for each scale. The direction will be displayed as a “1” or a “2” (the numbers are not assigned to a particular direction). You only need to change the count direction if the scale is counting in the negative direction during a positive move, or vice versa.

Refer to Conventions on pg. 29 for more guidelines.

To change the count direction:

- Move to the “Count Direction” display in the Setup mode. (Press **SETUP** and then the **ENTER** key until “Ct dir” appears).
- Press the appropriate axis key (**X**, **Y** or **Z**). The current count direction (1 or 2) will appear.
- After you complete setting your count direction, press **ENTER** to continue with setup or press **ENTER** then **SETUP** to return to the normal DRO display.

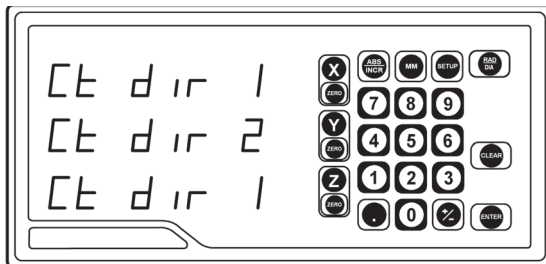

Radius/Diameter

The Radius/Diameter parameter determines which axes will be effected by the **RAD/DIA** key.

To change the Radius/Diameter mode:

- Move until the display reads “DIA” in the Setup mode. (Press **SETUP** and then the **ENTER** key until “DIA” appears). “1” indicates the Diameter mode will be enabled. “0” indicates it will disable the Diameter mode.
- Press the corresponding Axis key to enable or disable the Radius/Diameter mode.
- Press **ENTER** key once you have chosen the correct mode.

Position Recall

- Set this parameter to the ON position to store the last position of each axis when power is turned off.

Testing the Scales

Follow these steps to confirm that your scales have been installed properly. This test will confirm the scale’s electrical operation, and will also check the installation integrity.

Counting Test

- Move the tabel alon each axis, one at a time. Check that the readout corrcctly displays teh table’s movement. If it doesn’t, then the scale resolution you selected may not be accurate. Refer to Scale Resolution, pg. 9.

Repeatability Test

- Locate a magnetic base on the machine and set the dial indicator on the scale’s reading head casting. Zero the readout and the indicator.
- Move the axis through the full travel and return the dial to “0.” The readout should also read 0 (± 0.0005 ” for 10 μ m scales; ± 0.0002 ” for 5 μ m scales; ± 0.00005 ” for 1 μ m scales). If it doesn’t, then the scale cable may be loose, or the scale, mounting bracket, or reading head may need to be tightened or realigned.
- Repeat these steps for each scale.

Power On Position Recovery

With the **100S GP** there are two means of position recovery, Position Recall and Reference Mark Evaluation.

Position Recall

When this feature is active (see setup parameters) the last displayed position is stored in memory when power is lost or turned off. When power is restored, the stored position is recalled and displayed.

Note: Any movement that occurs while power is off will be lost. Whenever power has been off it is recommended that you re-establish workpiece datums using the Reference Mark Evaluation procedure below).

Operation

Reference Mark Evaluation

ENC 125 encoders contain internal reference marks, approximately 4" apart along the length of the encoder. These marks enable you to easily re-locate your correct position after a power interruption. You relocate your position, relative to the last established datums, by traversing across one reference mark on each encoder. You must find a convenient reference mark on each encoder prior to establishing your datums, and then use those same marks during the evaluation procedure, after a power interruption, to re-establish your position relative to your datums.

To perform Reference Mark Evaluation:

- Move near the appropriate reference mark.
- Press and hold the **DECIMAL** key until the decimal points on the displays start to flash
- Move slowly past the reference mark until the readout recalls its position.
- Repeat for each axis.

Radius and Diameter

Pressing the **RAD/DIA** key lets you view an axis dimension either as a radius or as a diameter. The **RADIUS/DIAMETER** parameter in Setup establishes which axis can be shown with either radius or diameter values.

Display resolution is affected by the **RAD/DIA** key.

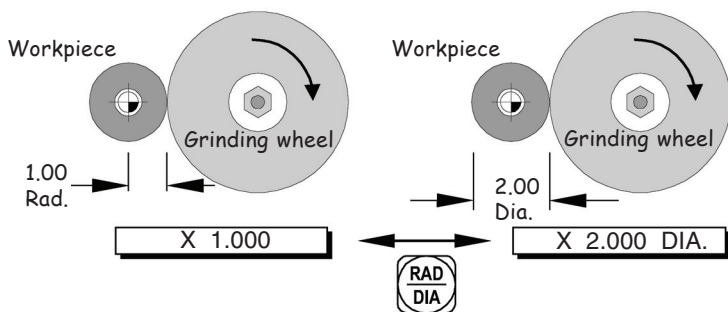

Setting the Datum (Absolute Zero)

100S GP allows you to measure both absolute and incremental dimensions. A dimension measured from the point you define as the datum is an absolute dimension. A dimension measured from any other point on your print is an incremental dimension.

Datum, also known as absolute zero or workpiece zero, is the reference point from which **100S GP** will base all of your part's coordinates. When the readout is in the ABS mode, it is actually measuring the distance from the datum to the machine axis' current position.

You will need to establish a datum for every job. Your datum may already be identified on your print; if isn't, then establish a datum that allows you to measure most of your part's dimensions directly, with the least number of calculations.

All of the dimensions in the drawing below are based from the datum.

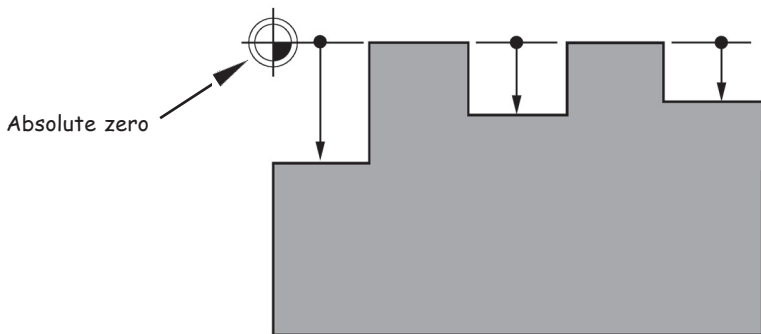

Operation

To set the datum at the tool's current position:

- Touch the wheel to the edge of the workpiece.
- Make sure the absolute position is displayed (ABS).
- Press the **ZERO** key of the appropriate axis.

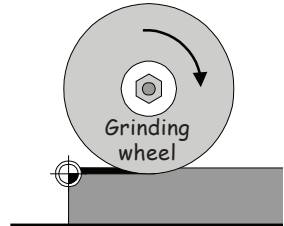

To set the datum using an offset:

- Using the **ABS/INCR** key, select the absolute (ABS) mode. Also check that the proper measurement (inch or mm) is selected.
- Using **RAD/DIA** key, select the Radius mode.
- Move the tool to a known point, i.e. the outside diameter of the workpiece or the face of the workpiece.
- Press the **ZERO** key once for the axis for which you are entering a dimension.
- Using the keypad, enter the distance from your tool's current location to the point you want to establish as the datum. Include a decimal point (.) and minus (-) sign when necessary.
- Press the **ZERO** key for the other axis, or press **ENTER** to return to the DRO display.

Incremental Dimensions

As described earlier, incremental dimensions are measured from the current tool position. If your tool is currently at 2" and you want to move an additional 3.125", you would select the incremental mode, zero out the axis, and move the axis until the display reads 3.125.

An example of how to measure using incremental dimensions is shown on the next page.

To use an incremental dimension:

- Move the machine axis to the point from where you want to measure an incremental distance.
- Use the **ABS/INCR** key to select the incremental (INCR) mode on the readout. Also check that the proper measurement (inch or mm) is selected.
- Press the **ZERO** key below the axis(es) from which you are measuring.
- Move the machine axis. **100S GP** will display the machine axis' position in relation to the incremental "0" point(s) for the axis(es) you chose.

After you have reached the position you want and have machined the part, you can "zero" each axis again and then measure from that location to the next point on your workpiece or press **ABS/INCR** to return to the absolute mode.

Operation

Example: Incremental Dimensions

Absolute and Incremental Displays

Absolute Display

Shows the distance from your current position to absolute zero.

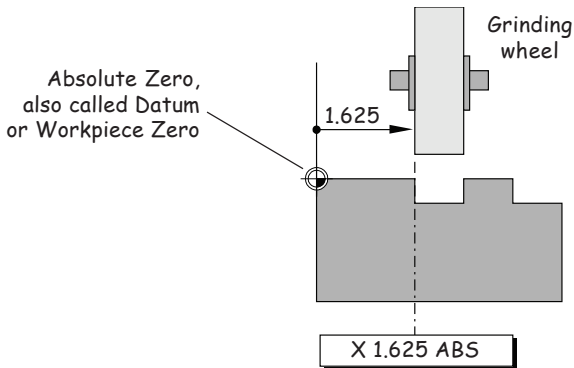

Incremental Display

Shows the distance from your current position to incremental zero. An incremental zero is set when you preset a dimension or zero the incremental display.

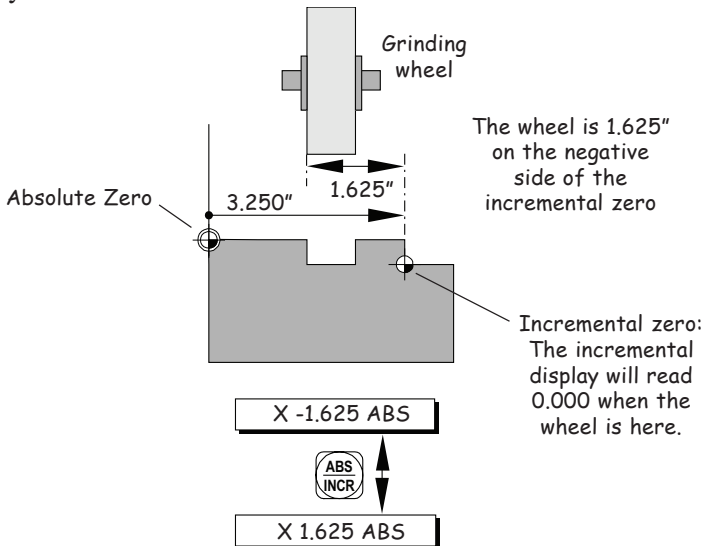

Absolute and Incremental Presets

To maintain the best tolerance and to minimize the chance for errors, use:

- absolute presets for absolute dimensions.
- incremental presets for incremental dimensions.

Ensure tht the **ABS** or the **INCR** LED is lit accordingly.

When you enter an absolute preset, it **does not matter** where the tool position is. The 100S GP calculates the desired location automatically.

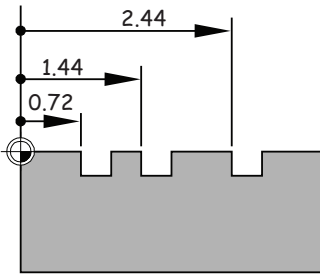

The display will show this.

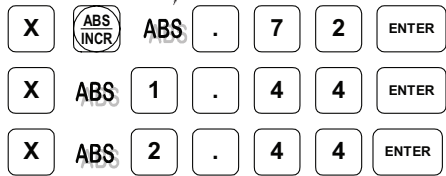

When you enter an incremental preset, the tool must be positioned at the location you are dimensioning from.

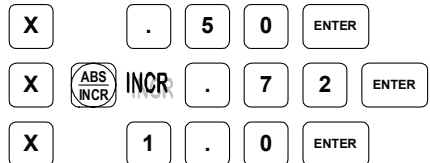
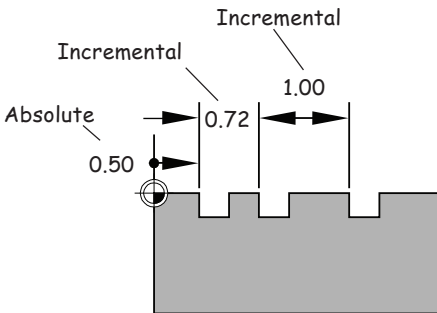

Troubleshooting

Troubleshooting Introduction

Refer to this troubleshooting guide whenever you have questions or concerns about the operation of your **100S GP** system.

This guide is arranged in three columns entitled Symptom, Probable Cause and Recommended Corrective Action. The symptoms are listed in the order of the most common, easiest to check, and least expensive to correct.

First locate the symptom that best describes the problem you are trying to solve. Then identify the probable cause that most closely matches the problem and implement the recommended corrective action.

If a problem persists or cannot be resolved using this manual, contact your **100S GP** distributor for further assistance.

Troubleshooting

Symptom	Probable Cause	Recommended Corrective Action
Dashes appear on screen	Display overflow	Move the axis toward the “0” position. As the scale counts down, the display will show the correct position.
Error message (E1) appears	Power loss occurred	This is a normal message at power up. If the message appears at any other time during operation, a problem may have occurred. Refer to pg. 23 for details.
Error messages (E2-E56) appear	Causes vary	Turn the system “off” and then “on” again, using the switch on the back of the readout. If an error (besides E1) is still detected when the system is powered up, contact your 100S GP distributor for repair/replacement procedures. Refer to pgs. 23 - 24 for a list of error messages.
Keys not working properly	Invalid keypress	Turn the system “off” and then “on” again, using the switch on the back of the readout. If an error (besides E1) is detected when the system is powered up, contact your 100S GP distributor for repair/replacement procedures. Refer to pg. 23-24 for a list of error messages.

Symptom	Probable Cause	Recommended Corrective Action
Scale won't count	Loose cable	Check that the scale cable is securely connected to the readout
	Wrong input	Check that the scale cable is connected to the correct input on the back of the readout.
	Scale not installed properly	Check the scale and reading head for proper installation (refer to scale installation instructions).
	The scale's reading head is not working	Unplug the scale from the readout and plug it into an input for another axis. If the scale still does not count, the reading head may need to be replaced. If the scale counts on the other axis then the display may need to be replaced. See LED Failure
Scale counts, but not correctly	Wrong count direction	Change the count direction (pg. 9).
	Scale not installed properly	Check the scale and reading head for proper installation (refer to scale installation instructions). Clean the scale if necessary.

Troubleshooting

Symptom	Probable Cause	Recommended Corrective Action
Setup does not save values	Improper procedure	Press the ENTER key after each parameter value is entered. If you press another key instead, the new value may not be saved. Refer to pgs. 5 - 10 for proper procedures.
Numbers don't appear/are faded on the display	LED failure	Turn the system "off" and then "on" again, using the switch on the back of the readout. If this does not correct the problem, contact your 100S GP distributor for repair/replacement procedures.

Error Messages (General)

When **100S GP** is powered up, it will run a series of tests to ensure that the software is working properly. If an error message appears, refer to the charts below for a diagnosis and solution.

E1	A power loss has occurred. This message will appear everytime you power up the system and can be cleared by pressing the CLEAR key. If the E1 message appears at any time other than at power up, a power interruption has occurred and your current position may be lost. Reestablish the datum if necessary. If the problem persists, contact your distributor for repair/replacement procedures.
E2	An EEPROM memory error has occurred. Press the CLEAR key to acknowledge the error. The datum and setup information may be lost. These areas should be checked and reestablished upon power up. If the problem persists, contact your distributor for repair/replacement procedures.
E3	A ROM memory error has occurred. Press the CLEAR key to acknowledge the error. If the system does not operate properly, contact your 100S GP distributor for repair/replacement procedures.
E4	A random access memory (RAM) error has occurred. Press the CLEAR key to acknowledge the error. If the system does not operate properly, contact your 100S GP distributor for repair/replacement procedures.
E9	A scale miscount error (invalid waveform) has occurred. The E9 message will appear on the axis that has the error. Press CLEAR to reset the axis(es). Your current position may be lost. Re-establish the datum if necessary. If the system does not operate properly, contact your 100S GP distributor for repair/replacement procedures.

Troubleshooting

Error Messages (Keypad Test)

The messages below indicate that a problem was found during the keypad test at startup. If an error message appears, turn the system off, press the appropriate key to release it back into position, and then restart the system. (Or you can press the **CLEAR** key to clear the error message.) If the key does not work during normal operation, contact your distributor for repair/replacement procedures.

E11	SETUP key	E38	1 Axis - X key 2 & 3 Axis - Y key
E12	RAD/DIA key	E41	3 key
E15	MM key	E45	2 key
E16	ABS/INCR key	E46	1 key
E18	X key	E48	1 Axis - ZERO key (X) 2 & 3 Axis - ZERO key (Y)
E21	9 key	E51	± key
E25	8 key	E54	ENTER key
E26	7 key	E55	0 key
E28	ZERO key for the X axis	E56	Decimal point (.) key
E31	6 key	E57	ZERO key for the Z axis
E33	CLEAR key	E58	Z key
E35	5 key		
E36	4 key		

Electrical Specifications

Follow these specifications when installing your **100S GP** system.

Characteristic	Specification
Operating conditions	0° to 40°C (32° to 104°F) 25% to 85% relative humidity (non-condensing)
Storage conditions	-40° to 60°C (-40° to 140°F) 25% to 85% relative humidity (non-condensing)
Input requirements: Voltage Frequency Current	100 - 240 V~ 50 - 60Hz 25 VA max
Fuse	500 mA, slo-blo
Scale input	Position signals: channels A & B TTL square wave signal in quadrature (90° nominal phase relationship) Maximum input rate: 70 kHz
Size	9.875" x 4.679" x 4.75"
Weight	4 lbs., 2 oz.
Mounting	Bottom; two 1/4"-20 threaded inserts
FCC compliance	This device complies with Part 15 of the FCC Rules. Operation is subject to the following two conditions: (1) this device may not cause harmful interference, and (2) this device must accept any interference received, including interference that may cause undesired operation.
CE compliance	For Europe
ETL compliance ETLc compliance	For United States For Canada

Factory Default Settings

Display Resolution	0.0005"/0.01 mm (10µm)
Linear Error	0 parts per million
Scale Resolution	0.0005"/0.01 mm (10µm)
Count Direction	1
Position Recall	Off
Radius/Diameter	Radius
Display Units	Inches
Display Mode	ABS (absolute dimensions)

Keypad

Here's an overview of the **100S GP** keypad. Each key's function is described below.

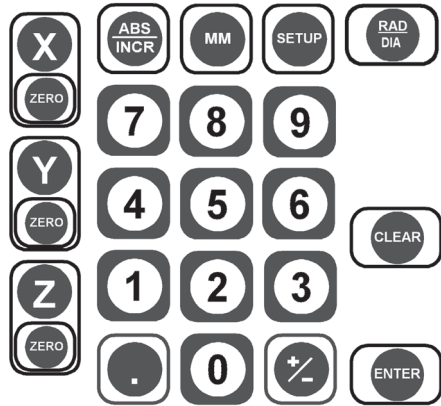

X, Y, Z (depending on how many axes are re	Correspond with the scales on the X, Y, and Z-axes. Used to specify a change to a particular axis.
ZERO	These keys reset the incremental or absolute display position at "0" for the corresponding axis.
ABS/INCR	Used to switch between absolute (ABS) and incremental (INCR) measurements. The active mode will be displayed at the top of the DRO display.
MM	Press this key to switch the X, Y and Z displays between English and metric units.
SETUP	Provides access to the display resolution, encoder resolution, position recall, linear error compensation, radius/diameter and scale count direction.
RAD/DIA	Used to switch between radius (RAD) and diameter (DIA) dimensions. The DIA indicator will light up when diameter is displayed.

Reference

CLEAR	Acts as backspace key during numeric entry; otherwise, it clears or cancels the last operation.
ENTER	Completes numeric operations; selects next parameter in SETUP .
±	Changes the sign of the entered value from positive (+) to negative (-) or vice versa. Numbers are positive unless a (-) appears in front of them.
▪	Decimal point can be used during numeric entry; also used to access the recall feature.
0-9	Used to enter a distance.

Conventions

This section identifies the standard conventions that apply to your **100S GP** system.

Count Direction

100S GP uses positive and negative numbers to determine the position of the table and tool on each axis. The graphic below shows a typical setup for the positive and negative count directions for the X-, Y-, and Z-axes. All of the examples in this manual are based upon this setup.

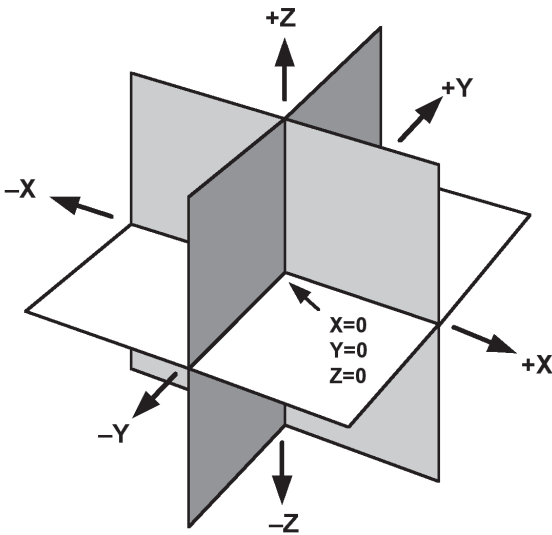

Warranty

ACU-RITE Companies, Inc. Products and accessories are warranted against defects in material and workmanship for a period of three (3) years from the date of purchase. ACU-RITE will, at its option and expense, repair or replace any part of the ACU-RITE product that fails to meet this warranty. This warranty covers both materials and factory labor. In addition, authorized ACU-RITE service representatives will provide service labor (field service) for a period of one (1) year at no charge. Notice of the claimed defect must be received by ACU-RITE within the warranty period.

This warranty applies only to products and accessories installed and operated in accordance with this reference manual. ACU-RITE shall have no obligation, with respect to any defect or other condition caused in whole or part by the customer's incorrect use, improper maintenance modification of the equipment, or by the repair or maintenance of the product by any person except those deemed qualified by ACU-RITE.

Responsibility for loss of operation or diminished performance due to conditions beyond ACU-RITE's control cannot be accepted by ACU-RITE.

The foregoing warranty obligations are in lieu of all expressed or implied warranties. ACU-RITE Companies, Inc. shall not be liable under any circumstances for consequential damages.

Hassle-Free Warranty

ACU-RITE Companies, Inc. is proud to offer the 3-Year Hassle-Free Warranty for all digital readout systems, vision readout systems and precision glass scales. This warranty will cover all of the ACU-RITE repair and replacement costs for any readout or precision glass scale returned during the three (3) year warranty period. ACU-RITE will repair or replace the damaged components - regardless of the product's condition absolutely free, no questions asked.





Acu-Rite Companies Inc.
IS AN
ISO 9001
CERTIFIED
MANUFACTURER



ACU-RITE[®]

Acu-Rite Companies Inc.

One Precision Way • Jamestown, NY 14701

532831-20 5/06

